

# Chapter E2 Stormwater and Flood Risk Management

Part E ► General Controls for All Development

CHAPTER E2 APPROVED ON 27 APRIL 2015

AND COMMENCED ON 23 MAY 2015

Last amended on 6 December 2021

Repealed by WDCP Amendment No. 30 on 2 December 2024

# Chapter E2 ► Stormwater and Flood Risk Management

## Contents

|  |  |           |
|--|--|-----------|
| <b>E2.1</b>  | <b>INTRODUCTION .....</b>  | <b>1</b>  |
|  | E2.1.1 Land and development to which this chapter applies .....  | 1         |
|  | E2.1.2 Development types to which this chapter applies .....   | 1         |
|  | E2.1.3 Objectives .....  | 1         |
|  | E2.1.4 Definitions .....   | 2         |
| <b>E2.2</b>  | <b>STORMWATER DRAINAGE MANAGEMENT CONTROLS.....</b>  | <b>3</b>  |
|  | E2.2.1 Introduction .....  | 3         |
|  | E2.2.2 Water sensitive urban design .....  | 4         |
|  | E2.2.3 Stormwater treatment .....  | 6         |
|  | E2.2.4 On site detention (OSD) of stormwater .....   | 8         |
|  | E2.2.5 Connection to Council’s drainage systems.....   | 11        |
|  | E2.2.6 Diversion of Council’s drainage .....   | 14        |
|  | E2.2.7 Structures over or near drainage lines and easements.....   | 15        |
|  | E2.2.8 Connection to Council’s parks, reserves, bushland and natural waterways;<br>Sydney Harbour; and Sydney Water channels ..... | 16        |
|  | E2.2.9 Low level properties and easements .....  | 17        |
|  | E2.2.10 Groundwater (hydrogeology) .....   | 19        |
|  | E2.2.11 Absorption systems .....   | 24        |
|  | E2.2.12 Pump and sump systems .....  | 25        |
|  | E2.2.13 Charged or siphonic systems .....  | 27        |
|  | E2.2.14 Activities on a public road .....  | 27        |
| <b>E2.3</b>  | <b>FLOOD RISK MANAGEMENT CONTROLS .....</b>  | <b>28</b> |
|  | E2.3.1 Introduction .....  | 28        |
|  | E2.3.2 Information available from Council .....  | 28        |
|  | E2.3.3 Flood planning levels .....   | 29        |
|  | E2.3.4 Flood controls.....   | 32        |
| <b>APPENDIX 1 - DEFINITIONS .....</b>                |  | <b>38</b> |
| <b>APPENDIX 2 - DESIGN RAINFALL INTENSITIES.....</b> |  | <b>43</b> |

Repealed by WDDP Amendment No. 30 on 2 December 2024

Repealed by WDCP Amendment No. 30 on 2 December 2024

## E2.1 Introduction

This chapter outlines provisions related to two key interrelated components:

- ▶ the management of stormwater drainage collected on and discharged from new developments; and
- ▶ the minimisation of flood related risks to person and property associated with the development and use of land.

In preparing an application for a development, both components must be considered.

### E2.1.1 Land and development to which this chapter applies

#### Stormwater drainage

This chapter applies to all land within the Woollahra Municipality.

#### Flood risk management

The flood risk management component of this chapter applies to all land within the Woollahra Municipality that is within a “flood risk precinct”.

### E2.1.2 Development types to which this chapter applies

This chapter applies to all development that requires consent.

This includes complying development under the NSW General Housing Code, and complying development for secondary dwellings under the *State Environmental Planning Policy (Affordable Rental Housing) 2009*.

### E2.1.3 Objectives

The objectives of this chapter are:

- 01 To encourage ecologically sustainable stormwater management and the use of water sensitive urban design.
- 02 To maintain existing natural drainage patterns.
- 03 To ensure that adequate provision has been made for the disposal of stormwater from land proposed to be developed.
- 04 To ensure the controlled release of stormwater to public stormwater systems without adversely impacting on adjoining or downstream properties.
- 05 To protect Sydney Harbour and its waterways from stormwater pollution.

- 
- 06 To minimise flood risk and damage to people and property by setting appropriate development controls.
- 07 To ensure that flood levels are not increased by development.

### E2.1.4 Definitions

---

The definitions in Appendix 1 of this chapter define words and expressions for the purpose of this chapter.

These definitions apply in addition to the definitions in Part A Chapter A3 of the DCP, and any other terms referred to in Australian Rainfall and Runoff (Institution of Engineers, Australia, 1987), the Floodplain Management Manual (New South Wales Government, January 2011), the *Environmental Planning and Assessment Act 1979* (EP&A Act) or the Woollahra Local Environmental Plan 2014 (LEP).

## E2.2 Stormwater drainage management controls

### E2.2.1 Introduction

In assessing development applications for stormwater drainage management, Council will consider each of the matters listed below and each matter must be addressed by the applicant. The response to these matters, plus any other relevant statutory and policy matters, will be considered by Council when assessing the acceptability of the development.

For each matter, specific objectives are given together with the controls to achieve those objectives. Alternative ways to achieve the stated objectives will be considered where, in the opinion of Council, the outcome is better in terms of the impact on the public domain or adjacent properties than strict compliance with the stated controls.

High quality submissions greatly aid the assessment process and it is recommended that information regarding the matters below be prepared by a suitably qualified practitioner.

Stormwater drainage management is generally achieved through the provision of a stormwater drainage concept plan, which should address the following management measures (where applicable):

- ▶ water sensitive urban design;
- ▶ stormwater treatment;
- ▶ on site detention (OSD) of stormwater;
- ▶ connection to Council's drainage systems;
- ▶ diversion of Council's drainage;
- ▶ structures over or near drainage lines and easements;
- ▶ connection to Council's parks, reserves, bushland and natural waterways; connection to Sydney Harbour; and connection to Sydney Water channels;
- ▶ low level properties and easements;
- ▶ groundwater (or hydrogeology);
- ▶ absorption systems;
- ▶ pump and sump systems;
- ▶ charged or siphonic systems; and
- ▶ activities on a public road.

Information regarding these matters does not necessarily have to be of a standard and level of detail that is construction ready. In most cases a concept plan only is required at DA stage, with the detailed stormwater drainage design and specifications required prior to the issue of a Construction Certificate. The exception to this is stormwater works impacting on easements, where detailed stormwater drainage design and specifications are required at the DA stage.

---

## E2.2.2 Water sensitive urban design

---

### Objectives

- O1 To ensure development is designed, constructed and maintained so as to minimise impacts on the natural water cycle.
- O2 To reduce peak stormwater flows and total stormwater runoff volume.
- O3 To utilise water resources more efficiently.
- O4 To reduce the flood risk in urban areas.
- O5 To reduce erosion of waterways, slopes and banks.
- O6 To control stormwater pollution and improve water quality in Sydney Harbour, waterways and drainage systems.

### Controls

#### *Pervious surfaces*

- C1 In areas with suitable ground conditions, the use of pervious surfaces is encouraged.

#### *Rainwater tanks*

- C2 The use of rainwater tanks for non-potable water uses is encouraged.
- C3 Rainwater tanks only collect roof water.
- C4 Rainwater tanks are connected to all external non-potable water uses including landscaping. Tanks may be connected to internal non-potable water uses including toilet flushing and washing machines.
- C5 Where OSD is required onsite (see Section E2.2.4), overflow from rainwater tanks is directed to the OSD system.
- C6 Where OSD is not required onsite, overflow from rainwater tanks is directed to Council's drainage network.
- C7 Rainwater tanks are located to minimise their visual impact. Above-ground rainwater tanks are located behind the building line and suitably screened. Slimline rainwater tanks at the side of buildings or under hardstand areas such as driveways are preferred.

#### Note:

- ▶ Rainwater tanks must be installed by a licenced plumber in accordance with AS3500 National Plumbing and Drainage Code, HB230 Rainwater Tank Design and Installation Handbook, other relevant codes and the manufacturer's specifications
- ▶ A positive covenant will be required for maintenance of rainwater tanks.



---

### ***Greywater reuse***

C8 The reuse of domestic greywater for non-potable water uses is encouraged (e.g. water discharged from washing machines).

Notes:

- ▶ A report on the appropriate treatment to allow for the safe reuse of domestic greywater must be prepared by a suitably qualified practitioner and the design must be in accordance with appropriate industry standards.
- ▶ Industry standards include HB 326 Urban Greywater Installation Handbook and the guidelines prepared by the NSW Department of Primary Industries (Office of Water), the NSW Department of Health and the Federal Department of Sustainability, Environment, Water, Population and Communities.
- ▶ A positive covenant will be required for maintenance of systems to reuse domestic greywater.

### ***Green roofs***

C9 The use of green roofs is encouraged.

Note:

- ▶ Green roofs must be designed by a suitably qualified practitioner and in accordance with appropriate industry standards.
- ▶ Industry standards include the Building Code of Australia and the City of Sydney Council Green Roof Resource Manual guidelines.
- ▶ A positive covenant will be required for maintenance of green roofs.

### E2.2.3 Stormwater treatment

---

#### Objectives

- O1 To minimise the discharge of pollutants (litter, sediment, suspended solids, nutrients, oil, grease and toxants) from paved and other impermeable surfaces into Sydney Harbour, waterways and drainage systems.

#### Controls

##### *Stormwater treatment*

- C1 Stormwater treatment is required for:
- all properties with connections to Sydney Harbour, waterways and open watercourses;
  - all new commercial developments and residential flat buildings; and
  - all major alterations and additions to commercial developments and residential flat buildings.
- C2 The stormwater treatment system, such as a gross pollutant trap (GPT), meets the specifications outlined in the water quality targets below (see control C7 below).
- C3 All stormwater treatment systems are located wholly on private property.

Note: A positive covenant will be required for maintenance of the stormwater treatment system.

##### *Rain gardens*

- C4 Rain gardens are required for:
- new developments where the total site area is more than 500m<sup>2</sup>;
  - developments involving alterations and additions where the additional gross impervious area is greater than 40m<sup>2</sup> and the total site area is more than 500m<sup>2</sup>; and
  - developments where the car park has four or more above ground parking spaces.
- C5 Rain gardens are sized as follows:
- 10m<sup>2</sup> per 1000m<sup>2</sup> of site area for sites between 500m<sup>2</sup> and 2,000m<sup>2</sup>; and
  - for sites greater than 2,000m<sup>2</sup>, the size of the required rain garden is to be determined by a study completed by a suitably qualified practitioner.

- C6 Council may consider a reduction in the size of the required rain garden if the applicant provides a detailed study by a suitably qualified practitioner. The study is to demonstrate that an integrated approach to water sensitive urban design has been undertaken and that the development meets Council's water quality targets. As a consequence, Council may require the OSD minimum site storage requirements to be increased to 25m<sup>3</sup> per 1,000m<sup>2</sup>. See Section 2.2.4 below for OSD requirements.

---

**Notes:**

- ▶ Rain gardens are to be designed by a suitably qualified practitioner and must be designed in accordance with appropriate industry standards.
- ▶ Industry standards include the Monash University's Facility for Advancing Water Biofiltration Adoption Guidelines and the NSW Government's Catchment Management Authority Water Sensitive Urban Design Program.
- ▶ A positive covenant will be required for maintenance of the rain garden.

**Water quality targets**

C7 Water quality measures are installed that meet the following environmental targets for stormwater runoff leaving the site:

- a) 90% removal of gross pollutants (> 5mm);
- b) 85% removal of total suspended solids;
- c) 65% removal of total phosphorous; and
- d) 45% removal of total nitrogen.

C8 For developments creating high levels of pollutants, pollution modelling may be required.

**Note:**

- ▶ Pollution modelling may be undertaken with programs such as MUSIC - the Model for Urban Stormwater Improvement Conceptualisation
- ▶ Discharge from car wash down bays, fire sprinkler test waters, trade wastes and wastes from air conditioning cooling towers are to be treated to Sydney Water's requirements and discharged to the sewer.

## E2.2.4 On site detention (OSD) of stormwater

### Objectives

- O1 To reduce and mitigate the peak stormwater flow from a developed site and allow the controlled release of stormwater to the public stormwater system.
- O2 To reduce flood risk in urban areas.

### Controls

#### Where this applies

- C1 OSD is required for:
  - a) new developments where the total site area is more than 500m<sup>2</sup>, and
  - b) developments involving alterations and additions where the additional gross impervious area is greater than 40m<sup>2</sup> and the total site area is more than 500m<sup>2</sup>.
- C2 Properties, regardless of the development type, located within Council's OSD exemption area are not required to install OSD.

Note: The map of Council's OSD exemption area is available on Council's website.

#### Requirements

- C3 OSD storage is designed in accordance with the storage/discharge relationships as shown in the table below.

| OSD requirements per 1,000m <sup>2</sup> of the total site area |   |            |
|---|---|------------|
| Permissible site discharge (l/s)                                | Minimum site storage requirements (m <sup>3</sup> ) | ARI (year) |
| 24  | 4   | 1 in 2     |
| 34  | 20  | 1 in 100   |

Note: The above OSD requirements are based on a simplified design approach which has been prepared using preliminary permissible site discharge and site storage requirement values. This simplified design approach will provide benefits to developers by reducing the cost of detailed engineering calculations, remove ambiguity in design approaches and assumptions, provide a simple geometric approach and allow Council to easily review designs with the intent of reducing development assessment times.

- C4 Council may consider independent assessment for on-site detention requirements. The applicant is to submit to Council an OSD assessment report including all modelling and design calculations. Any alternative methodology must be prepared by a suitably qualified practitioner.
- C5 Where possible, the drainage system is designed to direct runoff from the entire site to the OSD system.

- C6 Where OSD is required for alterations and additions, OSD is provided for the entire site, not only the area of new works.
- C7 All OSD systems drain by gravity to Council's drainage system.
- C8 An overland flow path, to convey water to the street in the event of a blockage or failure of the OSD outlet, is provided and is clearly identified in the design.
- C9 All OSD systems have a discharge limiter which is an appropriately sized short length of reduced diameter pipe or a non-removable orifice plate. The discharge limiter is enclosed by a rustproof screen or wire cage to protect against blockage.

**OSD location**

- C10 OSD storage is located as close as possible to the lowest point of the site and if possible at the property frontage so that any surcharge will overflow to the street.
- C11 Separate OSD is provided for each Torrens title dwelling.
- C12 For strata and subdivided properties, the OSD requirements outlined in controls C1 and C3 above apply to the property as a whole. OSD is generally located in common areas for strata title or community title subdivision.
- C13 The OSD structure is not established across property boundaries.

**Above ground storage**

- C14 The OSD system is visually unobtrusive and sympathetic with the development. It must not cause hazard or inconvenience to pedestrian or vehicle access.
- C15 A minimum 20% of the OSD storage requirement is incorporated as below ground storage.
- C16 OSD storage in landscaped areas requires an extra 20% volume to compensate for vegetation growth.
- C17 Pedestrian access paths are maintained above the 1 in 100 ARI operating level for any non-enclosed storage. Pounded water depths do not exceed 200mm in parking/ driveway areas, and 300mm in courtyards/grass/landscape areas.
- C18 Adequate subsoil drainage is provided in the above ground OSD storage to retain the amenity of the area after a rainfall event.

**Below ground storage**

- C19 The structural design of the OSD storage is certified by a suitably qualified practitioner including the following design issues:
  - a) all structures in the zone of influence of the excavation are checked for structural adequacy;
  - b) buoyancy of the OSD storage is taken into consideration; and
  - c) the OSD structure is designed to all relevant Australian Standards and industry standards; and

d) A minimum slope of 1% is provided on the floor of the OSD storage.

Note: Industry standards include AS 2865 Safe Working in a Confined Space and any Work Cover requirements.

### **Maintenance**

C20 The OSD system provides for easy access for inspection and maintenance. Generally, grated access points are preferred.

C21 A silt/ litter arrestor pit is located before the OSD storage and fitted with screens that can be easily removed for routine maintenance. The screen is of expanded steel mesh (e.g. Maximesh or similar). To assist in shedding debris, the screen is positioned no less than 45° to the horizontal. Pits are a minimum size of 0.6m x 0.6m.

Note: A positive covenant will be required for the maintenance of the OSD system.

### **Alternatives to OSD requirements**

C22 A rainwater tank may be installed as an alternative to all or part of the OSD requirements for any development type. The capacity of the rainwater tank is 1.5 times the OSD volume requirements. See Section E2.2.2 for rainwater tank requirements.

C23 A green roof may be installed as an alternative to part of the OSD requirements for any development type. The OSD requirements may be reduced by 50% if a roof garden is provided on-site. The roof garden covers at least 50% of the development's total roof area. See Section E2.2.2 for green roof requirements.

Note: Where there are discrepancies between the volume of OSD storage required in this chapter and the volume of OSD storage required in BASIX, the total storage requirements is the higher of the two volumes.

## E2.2.5 Connection to Council's drainage systems

---

### Objectives

- O1 To maintain existing natural drainage patterns and to not move water from one catchment to another.
- O2 To minimise erosion and allow for sediment control.
- O3 To avoid the flooding of properties.
- O4 To protect existing Council drainage assets.
- O5 To discharge stormwater at the lowest point feasible within the same catchment.

### Controls

#### General

- C1 Concept plans for the on-site stormwater system showing the location of major elements of the proposed system are provided.
- C2 Full details of the proposed connection to Council's drainage system are provided.
- C3 Where an overland flow system is not available, the drainage system is designed to cater to a minimum 1 in 100 ARI event.
- C4 Where an overland flow system is available, the drainage system is designed to cater to a minimum 1 in 20 ARI event; and the drainage system, in combination with the overland flow system, is designed to cater to a minimum 1 in 100 ARI event.
- C5 All stormwater discharge to Council's drainage system is gravity fed (for low level properties see also Section E2.2.9).
- C6 Stormwater discharge to the sewer is not permitted.
- C7 The potential for failure of components of the stormwater drainage system (e.g. blockage or structural damage) is considered and provision made for the safe conveyance of flows should failure occur.
- C8 Private drainage is installed in accordance with the appropriate industry standards.
- C9 All works within the road reserve or Council owned property comply with Council's "Specification for Road Works, Drainage and Miscellaneous Works".
- C10 Pumps for the disposal of stormwater runoff are not be permitted except in the circumstances set out in Section E2.2.12.

#### Note:

- Where works, including stormwater works, are within a public roadway (including the footpath and nature strip areas), approval is subject to a separate application under Section 138 of the *Roads Act 1993*.

- ▶ All construction costs associated with connection of the private stormwater discharge to Council's drainage system must be met by the applicant. The location of Council's drainage infrastructure is available by contacting Council's Drainage Engineer. The applicant is responsible for investigating and confirming the presence and suitability of Council's drainage system for connection. The applicant is responsible for investigating and confirming the presence of services and utilities within the road reserve (e.g. electricity, gas and water).
- ▶ Private drainage industry standards include AS3500 National Plumbing and Drainage Code, other relevant codes and the manufacturer's specifications.

### ***Connection to Council's below ground drainage***

#### *Where this applies*

- C11 In general, the stormwater drainage discharge from development sites is connected to Council's below ground drainage system.
- C12 Where there is no Council drainage system located adjacent to the site, the applicant must extend Council's drainage system to the site in order to permit the below ground connection.

#### *Requirements*

- C13 The connection from the development site to Council's below ground drainage system is a direct route and is generally laid perpendicular to the line of the kerb and gutter.
- C14 Stormwater drainage lines are located under the kerb and gutter where possible.
- C15 All connection pits are constructed in accordance with the appropriate industry standards.
- C16 No portion of the connection pipe intrudes into Council's pipe.
- C17 All stormwater pipes within the road carriageway are designed and installed to meet Council's specifications.
- C18 A standard Council double grated gully pit with 1.8m kerb lintel is constructed over the new line where it intersects with the private stormwater line. A capped pipe stub is provided to enable future extension of the line upstream.

#### *Notes:*

- ▶ Connection pit industry standards include AS3500 National Plumbing and Drainage Code, other relevant codes and the manufacturer's specifications.
- ▶ A closed circuit television (CCTV) inspection of any new connection must be carried out and submitted to Council with a works-as-executed plan.
- ▶ All stormwater pipes within the road carriageway must be at a minimum Class 2, 375mm diameter and have bedding to standard HS3, in accordance with AS3725 Loads on Buried Concrete Pipes. Rubber ring joints are required.



*Exemptions*

- C19 An exemption from the requirement to discharge directly into Council’s below ground drainage system may be considered where the required extension of Council’s system is excessive. This exemption will be considered on a merit based assessment and factors to be considered include the magnitude of the development, extent of required works and the suitability of an alternative option.

**Connection to Council’s kerb and gutter**

*Where this applies*

- C20 Only dwelling houses and developments involving alterations and additions, where the additional gross impervious area is less than 40m<sup>2</sup>, may discharge stormwater to the kerb and gutter.

*Requirements*

- C21 The connection from the development site to Council’s kerb and gutter is a direct route.
- C22 A maximum discharge rate of 20 l/s is permitted.
- C23 A maximum of one stormwater outlet per property is permitted.
- C24 Drainage conduits, across footpath areas that are discharging to the kerb, are designed and installed to meet Council’s specifications.
- C25 Where the existing kerb is sandstone, the drainage discharge point is cored. The kerb is reinstated to match the existing form (e.g. bullnose, brick and sandstone).

Note: Drainage conduits, across footpath areas that are discharging to the kerb, must be 125mm x 75mm galvanised box or 65mm to 100mm sewer grade PVC pipes.  
A kerb adaptor must be provided for 80mm and 100mm PVC pipes.

**Subsoil drainage**

- C26 All below ground structures with habitable or non-habitable floor spaces are fully tanked and do not require permanent dewatering.
- C27 All below ground structures are designed and installed in accordance with Council’s Guide for preparing Geotechnical and Hydrogeological Reports.
- C28 Subsoil drainage does not discharged to Council’s stormwater network, including stormwater pipes, pits and/or kerb and gutter.

---

## E2.2.6 Diversion of Council's drainage

---

### Objectives

- O1 There is to be no adverse impact on upstream or downstream properties.
- O2 There is to be no adverse impact on Council's drainage system.

### Controls

- C1 If an applicant proposes to divert Council's drainage the application is accompanied by a report, prepared by a suitably qualified practitioner, on the impacts of the diversion.
- C2 Where an overland flow system is not available, the diverted drainage system is designed to cater to a minimum 1 in 100 ARI event.
- C3 Where an overland flow system is available, the diverted drainage system is designed to cater to a minimum 1 in 20 ARI event; and the drainage system, in combination with the overland flow system, is designed to cater to a minimum 1 in 100 ARI event.
- C4 If Council's existing drainage system is diverted onto private land, an easement is created in favour of Council (see Section E2.2.9).

### Notes:

- ▶ A dilapidation report including a CCTV inspection of all drainage lines being impacted or diverted must be submitted with the construction certificate application. If the existing drainage line is in poor condition the drainage line is to be renewed and/ or refurbished.
- ▶ The location of the diverted drainage system must be fully accessible for future maintenance.

### E2.2.7 Structures over or near drainage lines and easements

#### Objectives

- O1 To provide for future maintenance activities on drainage lines.
- O2 To provide and maintain adequate overland flow paths.

#### Controls

- C1 Generally, new buildings, structures and overhanging structures are not permitted over existing or proposed drainage lines and easements.
- C2 All structural foundations adjoining an easement or drainage line have a minimum depth lower than the invert of the adjacent drainage line. Additional depth is required for foundations adjoining natural water courses. All foundations are designed by a suitably qualified practitioner.
- C3 Overland flow paths are maintained over drainage lines and easements. Driveways and landscaped areas may be located on overland flow paths.

Note:

- Applications must include plans and details relating to structures near a Council drainage line or easement.
- A dilapidation report including a CCTV inspection of all drainage lines within 3m of any development structure must be submitted with the construction certificate application. If the existing drainage line is in poor condition the drainage line is to be renewed and/or refurbished.
- The applicant is to submit details on the proposed construction methodology to ensure that Council’s drainage system is protected and supported during any works.

**FIGURE 1** Typical section showing the zone of influence

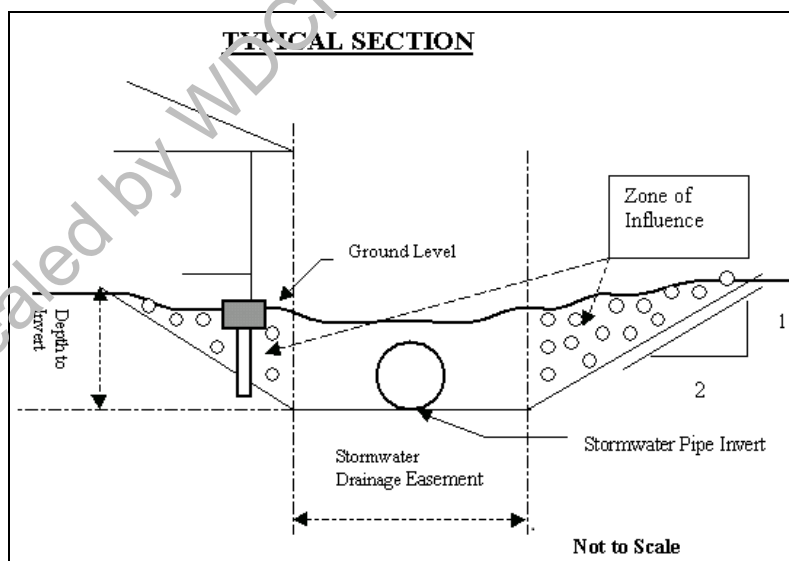

---

## E2.2.8 Connection to Council's parks, reserves, bushland and natural waterways; Sydney Harbour; and Sydney Water channels

---

### Objectives

- O1 To manage, conserve and protect Council parks, reserves, bushland and natural waterways.
- O2 To maintain existing natural drainage patterns.
- O3 To minimise erosion of waterways, slopes and banks.
- O4 To control stormwater pollution and improve water quality in streams and groundwater.

### Controls

#### General

- C1 Stormwater discharge to a natural watercourse or Council below ground drainage line within a Council park, reserve or bushland may be permitted subject to a merits based assessment of the proposal by Council's Open Space and Trees Department.
- C2 An environmental impact assessment is submitted addressing the impact on the park, reserve or bushland during and after construction, environmental sensitivity, erosion potential and weed invasion potential.
- C3 Stormwater pipes and other structures are not visible on public land. Outlet structures are designed to blend in with the surrounds and should be constructed of natural materials, such as rock.

Note: Access through Council's park land and/ or storage of material on Council park land during construction will not be permitted unless prior written approval has been obtained from Council's Open Space and Trees Department.

#### Discharge directly to Sydney Harbour

- C4 Written approval from the Waterways Authority to discharge stormwater into Sydney Harbour is required.

Note: The applicant must seek this approval. The stormwater system must be designed in accordance with this DCP and any requirements of the Waterways Authority.

#### Discharge to Sydney Water channels

- C5 Written approval from Sydney Water to discharge stormwater from the subject property directly into Sydney Water drainage channels is required.

Note: The applicant must seek this approval. The stormwater system must be designed in accordance with this DCP and any requirements of Sydney Water.

## E2.2.9 Low level properties and easements

### Objectives

- O1 To maintain existing natural drainage patterns.
- O2 To ensure drainage discharge associated with new developments is gravity fed and does not require pumps to function.
- O3 To avoid nuisance and flooding.
- O4 To provide effective overland flow paths.
- O5 To protect existing Council drainage assets.
- O6 To discharge stormwater at the lowest point feasible within the same catchment.

### Controls

#### Requirements

- C1 Drainage discharge to Council’s stormwater system is gravity fed. This may require the creation of an easement through the downstream property to discharge stormwater from the subject property.
- C2 Where an overland flow system is not available, the drainage system is designed to cater to a minimum 1 in 100 ARI event.
- C3 Where an overland flow system is available, the drainage system is designed to cater to a minimum 1 in 20 ARI event; and the drainage system, in combination with the overland flow system, is designed to cater to a minimum 1 in 100 ARI event.

#### Easements

- C4 Where easement consent is granted:
  - a) The easement is created on the certificate of title for all impacted properties.
  - b) The private drainage easement is of sufficient width to allow the required pipe to be installed and maintained.

Note: Any costs associated with investigating or establishing the easement are the responsibility of the applicant.

The applicant is responsible for negotiating with the downstream property owner to obtain a private drainage easement. It is not Council’s role or within Council’s jurisdiction to adjudicate on amounts of compensation. It is recommended that independent legal advice be sought.

Possible options available to acquire a private drainage easement include:

- ▶ by direct negotiation
- ▶ Section 88K of the *Conveyancing Act 1919*
- ▶ Section 40 of the *Land and Environment Court Act 1979*

The applicant must make a reasonable attempt to provide a gravity feed system to drain the site. The applicant must make formal approaches to all possible downstream property owners.

The applicant must attach a copy of the formal consent from the owner(s) of the intervening downstream property(s) with the development application.

The applicants must also engage a registered surveyor to prepare a plan of survey and the application for the easement must be lodged with the Land Titles Office with any necessary fees. Woollahra Council must be annotated as the Prescribed Authority on the Section 88K Instrument. A copy of the lodgement details must be provided to Council prior to operation of any development consent or activity application.

The requirement to obtain an easement may be waived if:

- ▶ written documentary evidence of refusal to permit an easement by the downstream owner has been provided to Council; and
- ▶ written documentary evidence of all reasonable attempts undertaken by the applicant to obtain an easement through the downstream property; and/or
- ▶ evidence is provided of any physical constraint that precludes a route for a downstream system.

For larger developments or developments in areas with known drainage problems, Council may require the applicant to pursue the acquisition of a downstream easement through the Land and Environment Court.

If an easement is not obtainable, it may be possible to connect to Council's below ground stormwater system if the Council system is extended to the site. See Section 2.2.5 above for requirements.

### ***Easement alternatives***

- C5 Easement alternatives will be considered only where the development involves alterations and additions to a dwelling house; and where the development increases the impervious area of the site by less than 40m<sup>2</sup>.
- C6 The following easement alternatives may be considered in the following circumstances:
- a) Where all roof drainage is drained to a rain tank designed to hold a volume of water and the tank only overflows once a year, on average. The minimum acceptable tank size is 60m<sup>2</sup> per 1,000m<sup>2</sup> of site area.  
Note: The applicant must submit full water balance calculations prepared by a suitably qualified practitioner.
  - b) Where an absorption dispersal system downstream of the rain tank and any paved areas is provided, and the absorption system is designed for a 20 year ARI storm. The rain tank is to be assumed to be full. See Section E2.2.11 for absorption system requirements.
  - c) Where the area is unsuitable for an absorption system, 20% extra storage volume is provided in the rain tank and a pump system may be installed. See Section E2.2.12 for pump system requirements.

Note: Council may reduce the storage requirements in heritage conservation areas if space is limited. This will be assessed on the merits of the application.

### ***Relationship to other properties***

- C7 Where surface runoff from adjoining properties currently flows onto the subject site, such flows are catered for within the development. Obstructions that cause damming and backwater effects on upstream properties will not be permitted.
- C8 Surface runoff from the subject site is not concentrated onto downstream properties.

### ***Existing Council stormwater***

- C9 Council will require the creation of an easement to its benefit over existing Council stormwater pipes, boxes or channels on private land.

## **E2.2.10 Groundwater (hydrogeology)**

---

### **Introduction**

Council will require geotechnical and hydrogeological reports for development applications which include below ground structures.

Any proposed development with below ground structures must consider the sub-surface conditions and the effects of construction on surrounding properties. In addition, those which are likely to extend below the level of seasonal fluctuations in the groundwater table, must also consider the effect of any changes induced in the sub-surface water levels and the groundwater flow patterns on surrounding properties. Unless site specific information exists to the contrary,

excavations deeper than 1m must be assumed to have this potential to intersect the groundwater level and shall be considered as below ground structures.

Council's principal objective is to ensure that earthworks and associated groundwater dewatering, during and after construction, will not have any adverse impacts on:

- ▶ Environmental functions and processes
- ▶ Neighbouring uses
- ▶ Cultural and heritage items
- ▶ Any features of the surrounding land and infrastructure that could be impacted by geotechnical and hydrogeological changes.

Typically, adverse geotechnical impacts may include vibration induces settlements from construction methods and equipment and inadequate support of adjacent land during and after construction. Typically, adverse hydrogeological impacts may include settlement induced by changes in the groundwater level and seepage problems.

Repealed by WDCP Amendment No. 30 on 2 December 2024



## Objectives

- 01 To ensure that earthworks and associated ground water dewatering, during and after construction, will not have any adverse impacts on:
- Environmental functions and processes
  - Neighbouring uses
  - Cultural and heritage items
  - Any features of the surrounding land and infrastructure that could be impacted by geotechnical and hydrogeological changes.
- 02 To maintain the existing groundwater level, both during and after construction.
- 03 To minimise changes in groundwater level to protect surrounding property and infrastructure from damage.
- 04 Buildings must be designed and constructed with appropriate support and retention systems to ensure that:
- a) There will be no ground settlement or movement, during and after construction, sufficient to cause an adverse impact on surrounding properties and infrastructure.
  - b) Vibration during construction is minimised or eliminated to ensure no adverse impact on surrounding properties and infrastructure.
  - c) The risk of damage to adjacent existing property and infrastructure by the new development will be reduced to a level no greater than that from an event with an “unlikely” likelihood of occurrence and “minor” consequence.

Note: “adverse impact” means any damage caused to the improvements on adjoining properties by the demolition, excavation or construction on the development site.

## Controls

### **General controls that apply to the entire LGA.**

- C1 Unless site specific information exists to the contrary, excavations deeper than 1m are assumed to have a potential impact on groundwater.

Note: Where the groundwater level is high, any proposed development with below-ground structures must consider the sub-surface conditions and the impacts of construction on surrounding properties.

Below-ground structures which are likely to extend below the level of seasonal fluctuations in the groundwater table, must also consider the impact of any changes induced in the sub-surface water levels and the groundwater flow patterns on surrounding properties.

### **Requirements**

- C2 All below-ground structures are fully tanked. These type of structures must not collect and dispose of subsoil/seepage to kerb and gutter.
- C3 Groundwater does not discharged to Council’s stormwater network, including stormwater pipes, pits and/or kerb and gutter.

---

Notes:

All below-ground works must also comply with the requirements of the NSW Department of Primary Industries Office of Water.

The design statement must confirm that the design of the below-ground structure has been undertaken in accordance with the relevant Australian Standards where applicable.

C4 Development applications which include below ground structures must include the following documents:

- a) Structural report
- b) Geotechnical and hydrogeological reports
- c) Design statement and supporting drawings that show the design measures proposed to minimise risks and to ensure that no adverse impacts will occur.

Note: Council may identify other circumstances where these reports are required. All reports must be prepared in accordance with Council's guidelines. Council may also require the preparation and submission of a pre-commencement dilapidation report for properties neighbouring the development.

C5 A qualified and experienced geotechnical and/or hydrogeological engineer must prepare the reports.

The reports must include a site-specific risk assessment matrix with appropriate definitions for qualitative measures of likelihood and consequences for assessing the risk of damage to existing developments by the new development.

C6 Where groundwater is present and dewatering is likely to occur on the site, the requirements of Council's DA Guide under the 'Investigations' section must be implemented.

C7 Any geotechnical and hydrogeological reports must contain an Implementation Plan, including a Monitoring Program, Contingency Plan and Construction Methodology.

Note: All reports and requirements must be prepared in accordance with Council's DA Guide. Geotechnical reports must be prepared by an appropriately qualified Geotechnical Engineer who is NER registered with a minimum of 10 years practice in the geotechnical field in the last 15 years.

**Land in the Double Bay settlement area**

In addition to the general controls in this section, the following applies to the land in the Double Bay settlement area, as shown below.

**FIGURE 1 Double Bay settlement area**

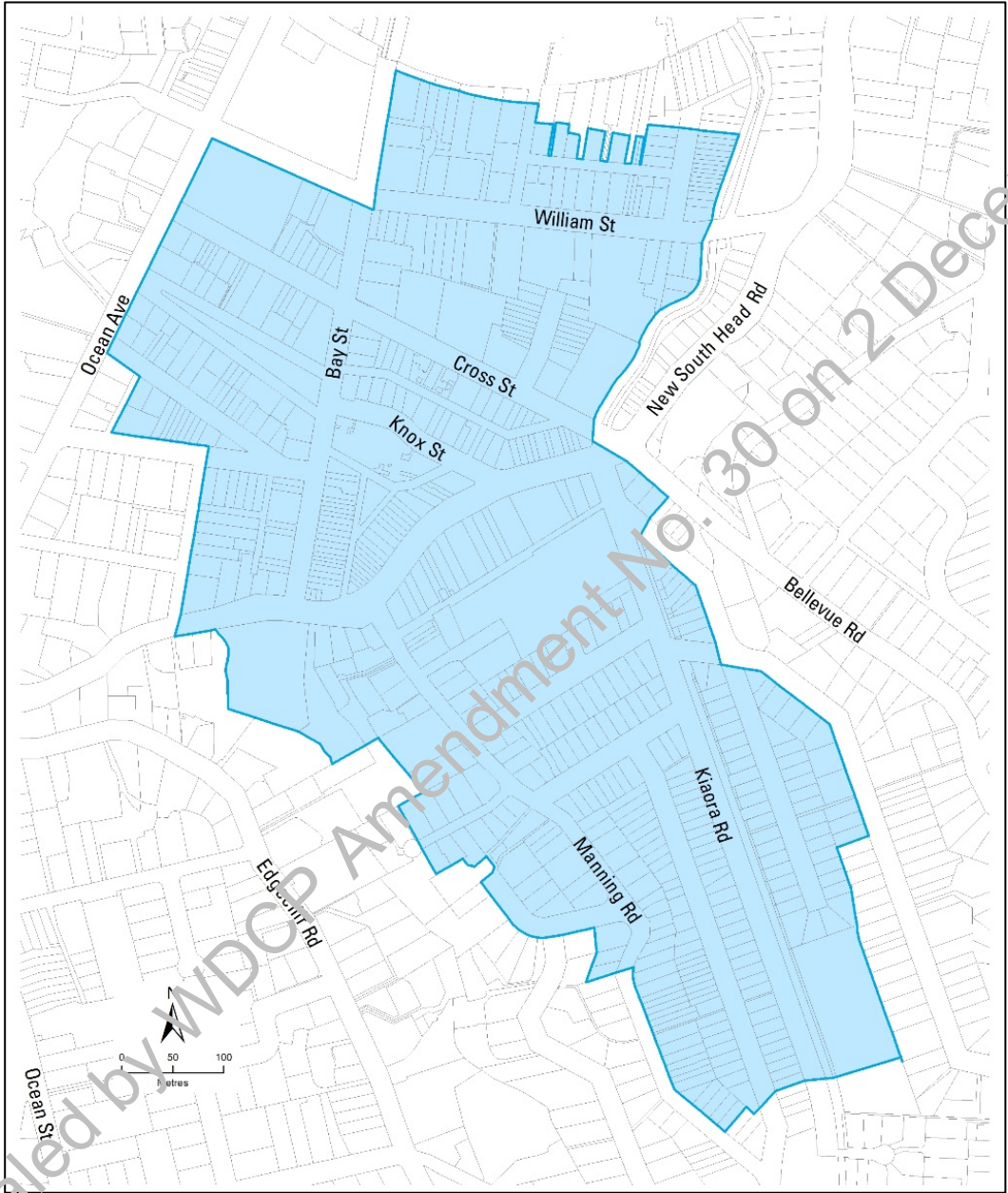

C8 Temporary changes to the groundwater level, due to construction, must not exceed 0.2 m from the average monitored pre-construction groundwater level unless calculations using the results of specific field testing, support a greater change and demonstrate that the change will not induce settlement greater than the characteristic surface movement of a Class S site as defined in Table 2.3 of Australian Standard AS2870-2011.

---

## E2.2.11 Absorption systems

---

### Objectives

- O1 To ensure development is designed, constructed and maintained so as to minimise impacts on the natural water cycle.
- O2 To reduce peak stormwater flows and total stormwater runoff volume.
- O3 To reduce the flood risk in urban areas.
- O4 To minimise stormwater impacts on downstream properties.

### Controls

#### *Where this applies*

- C1 Absorption systems may only be utilised where it is not possible to discharge drainage to Council's stormwater system by gravity.
- C2 Absorption systems will not be considered if easements, inter-allotment drains or drainage reserves are available to provide gravity feed access to Council's stormwater system.

#### *Requirements*

- C3 Absorption systems are designed to adequately contain the difference between inflow and outflow rates, depending on the permeability of the soil.
- C4 Generally the minimum soil depth to rock is 1.5m. However, in harbourside locations, a lesser value may be accepted. This will be assessed on the merits of the application.
- C5 Properties seeking to install an absorption system also install a rainwater tank in accordance with Section 2.2.2. The rainwater tank is at least 6m<sup>3</sup> per 100m<sup>2</sup> of impervious area across the site. The purpose of the rainwater tank is to reduce the quantity of water going to the absorption system.
- C6 The design addresses the impact of increased subsoil flow on properties downstream of the absorption trench, and details of the impact of the absorption pit on the downstream catchment are submitted.
- C7 Approval will not be provided where the nominal absorption rate is less than 0.1 litres/m<sup>2</sup>/s strata of impermeable or low permeability material are present, or where the water table is less than 2m from the base of the pit.

Notes: Applications for an absorption system must be accompanied by a concept plan showing the location, dimensions and levels of the proposed system. Applications for absorption systems must be prepared by a suitably qualified practitioner and comply with Council's Guide for preparing Geotechnical and Hydrogeological Reports.

Applications for an absorption system must be accompanied by a Geotechnical Report to accurately determine the following soil characteristics: the soil type/s to a depth of at least 2m, the nominal absorption rate, the depth to an identification of any strata through the soil and the depth of the water table. The soil characteristics must be determined using appropriate field tests.

---

## E2.2.12 Pump and sump systems

---

### Objectives

- O1 To mitigate the impacts of pumping water to areas that would normally not receive discharge.
- O2 To avoid the flooding of properties.
- O3 To protect existing Council drainage assets.

### Controls

#### *Where this applies*

- C1 Pump and sump systems will only be considered where the development involves alterations and additions to a dwelling house, and where the development increases the impervious area of the site by less than 40m<sup>2</sup>.
- C2 The pump and sump system may only be utilised for the development additions. That is, a pump and sump system may not be retrofitted to the component or sections of the building which are existing.

#### *Requirements*

- C3 The collection system for the pump and sump arrangement is designed in accordance with the design criteria for gravity drainage in this chapter.
- C4 The pump and sump system are designed by a suitably qualified practitioner and designed and installed in accordance with the appropriate industry standards.
- C5 Properties seeking to install a pump and sump system also install a rainwater tank in accordance with Section E2.2.2. The rainwater tank is at least 6m<sup>3</sup> per 100m<sup>2</sup> of impervious area across the site. The purpose of the rainwater tank is to reduce the quantity of water going to the pump and sump system.
- C6 The tank has an automatic pump which meets the following requirements:
  - a) The pump may only commence pumping a minimum of 1 hour after rain has ceased.
  - b) The pump may only operate when the rainwater tank is over 50% full.
  - c) The pump may only pump out the top 50% of the rainwater tank (the remaining water is to be available for reuse).
  - d) At a minimum, the pump out system must consist of dual alternating pumps and be connected to an uninterrupted power supply.
- C7 Discharge from the site does not exceed the permissible site discharge as outlined in Section 2.2.4 control C3.
- C8 In the event of the failure of both pumps, an overland flow path and/or surcharge and pondage area is identified and provided.

- 
- C9 Discharge from the system passes through a stilling pit, located within the site boundary. Discharge to Council's underground stormwater system is via a concrete pipe with a minimum diameter of 375mm and a new stormwater junction pit located in the public road.
  - C10 The pump and sump system is protected from backflow from Council's drainage system.
  - C11 All electrical fittings and supply are 500mm above the maximum water level and/or any overland flow paths.

**Location**

- C12 Pressured pipes are only permitted on the applicant's property. Council will not approve the use of pressurised pipe systems within the road reserve or Council owned property.

Note: Industry standards include AS3500 National Plumbing and Drainage Code, other relevant codes and the manufacturer's specifications.

A positive covenant will be required for the maintenance of the pump and sump system.

### E2.2.13 Charged or siphonic systems

---

#### Objectives

- O1 To protect existing Council drainage assets.

#### Controls

##### *Where this applies*

- C1 Non-mechanical pressurised (charged or siphonic) systems will only be considered where it is not possible to discharge drainage to Council's stormwater system by gravity.

##### *Requirements*

- C2 The charged or siphonic system is designed by a suitably qualified practitioner and designed and installed in accordance with the appropriate industry standards.
- C3 In general, the discharge from charged or siphonic systems are connected to Council's below ground drainage system.
- C4 Only dwelling houses and developments involving alterations and additions, where the additional gross impervious area is less than 40<sup>m</sup><sup>2</sup>, may discharge from the charged or siphonic systems to the kerb and gutter.
- C5 Discharge from the system passes through a stilling pit, located within the site boundary.
- C6 The system is protected from backflow from Council's drainage system.  
 Note: Industry standards include AS5500 National Plumbing and Drainage Code, other relevant codes and the manufacturer's specifications.

### E2.2.14 Activities on a public road

---

#### Objective

- O1 To protect Council's road assets.
- O2 To ensure works carried out on Council's road and stormwater assets meet Council's required standard.

#### Controls

- C1 All works, including stormwater works, within a public roadway are in accordance with Council's "Specification for Road Works, Drainage and Miscellaneous Works".  
 Note: Where works, including stormwater works, are within a public roadway (including the footpath and nature strip areas), approval is subject to a separate application under Section 138 of the *Roads Act 1993*. The nominated principal certifying authority cannot legally give approval for works under Section 138 of the *Roads Act*. Approval must be granted by Council.

## E2.3 Flood risk management controls

### E2.3.1 Introduction

In assessing development applications for flood risk management within “flood risk precincts”, Council will consider each of the matters listed below and each matter must be addressed by the applicant. The response to these matters, plus any other relevant statutory and policy matters, will be considered by Council when assessing the acceptability of the development.

For each matter, specific objectives are given together with the controls to achieve those objectives. Alternative ways to achieve the stated objectives, will be considered when, in the opinion of Council, the outcome is better in terms of the impact on the public domain or adjacent properties than strict compliance with the stated controls.

The flood risk planning controls reflect the recommendations of the Woollahra Coastal Zone Management Plan, and the Floodplain Risk Management Plans for Double Bay, Rose Bay and Rushcutters Bay and the Updated Flood Study for Watsons Bay, prepared in accordance with the State Government Flood Prone Lands Policy and the Floodplain Development Manual.

### E2.3.2 Information available from Council

Council will make available information on flooding, coastal inundation and the Council drainage system, where it is available, on the express understanding that Council is not liable for the accuracy of the information or the consequences of it being used.

There are four main floodplains within the Woollahra Municipality:

- ▶ Rushcutters Bay
- ▶ Double Bay
- ▶ Rose Bay
- ▶ Watsons Bay.

Each of the floodplains can be classified based on different levels of potential flood risk. Flood information, including flood levels as derived from significant historical flood events, is available on each of these floodplain areas. This information may be found on Council’s website.

A Woollahra Coastal Zone Management Plan Stage 1 report has been prepared for the Woollahra Municipality. Estuary Planning Levels have been developed for those properties subject to coastal inundation.

The applicant must confirm the accuracy of information by inspection, survey and/or study. Where existing flood or coastal inundation information is not available but flooding and/or coastal inundation is considered by Council to be a potential issue, a site specific study may be required.



---

### E2.3.3 Flood planning levels

---

Flood planning levels (FPLs) set the floor level height for development in areas which are subject to flooding. The FPLs vary depending on the relative flood risk and the proposed development type.

FPLs consist of the following:

- ▶ a flood level which has been determined from a flood study (see Section E2.3.2); plus
- ▶ a freeboard that compensates for uncertainties in the estimation of flood levels across the floodplain.

#### Foreshore developments subject to coastal inundation

Foreshore developments subject to coastal inundation must give consideration to two factors:

- ▶ flood planning levels (FPLs); and
- ▶ estuary planning levels (EPLs).

EPLs consist of the following:

- ▶ a still water level which has been determined from a coastal inundation study (see Section E2.3.2); plus
- ▶ a local wind and wave setup height which has been determined from a coastal inundation study (see Section E2.3.2); plus
- ▶ a wave run-up/overtopping height which has been determined from a coastal inundation study (see Section E2.3.2); plus
- ▶ a sea level rise factor; plus
- ▶ a freeboard that compensates for uncertainties in the estimation of coastal inundation levels across the coastal zone.

Note: The NSW Chief Scientist has advised that the sea level rise benchmarks (measured as an increase above 1990 mean sea levels) of 40cm by 2050 and 90cm by 2100 are adequate in light of evolving understanding of the complex issues surrounding future sea levels.

All EPLs should be based on the 2100 benchmark.

#### Objectives

- 01 To minimise risk to people and property.
- 02 To reduce the long term risks associated with coastal inundation, elevated sea levels and/or waves overtopping foreshore defences.
- 03 To maintain Council's streetscape objectives in existing commercial and heritage areas.

## Controls

- C1 All new developments and major alterations and additions have their floor levels set at the required FPL and EPL as stipulated in the following table:

| Development type   | Flood (and estuary) planning level   |
|--|--|
| Habitable floor areas  | 100 Year ARI flood level plus 0.5m freeboard   |
| Non-habitable floor areas  | 100 Year ARI flood level plus 0.3m freeboard   |
| Habitable floor areas for foreshore developments subject to coastal inundation | The highest RL, calculated from the following: <ul style="list-style-type: none"> <li>▶ 100 Year ARI flood level plus 0.5m freeboard; or</li> <li>▶ still water level plus 100 Year ARI wave run-up plus 0.3m freeboard</li> </ul> |
| Ground level, open car parking spaces  | 20 Year ARI flood level plus 0.3m freeboard  |
| Enclosed car parking spaces, three or fewer vehicles                           | 20 Year ARI flood level plus 0.3m freeboard  |
| Enclosed car parking spaces, more than three vehicles                          | 100 Year ARI flood level plus 0.3m freeboard   |

- C2 For alterations and/or additions (only) developments, where it is not practical to meet the above habitable, non-habitable and car parking floor levels due to compatibility with the height of adjacent buildings, or compatibility with the floor level of existing buildings, a lower floor level may be considered, based on the individual merits.

A lower floor level will only be permitted where the habitable floor area increases by 40m<sup>2</sup> or less. In these circumstances, the floor level is to be as high as practical, and no lower than the existing floor level. This concession will be made no more than once for any given property. Subsequent development applications will be required to meet the FPLs and EPLs as outlined in C1.

- C3 To achieve the required FPL and/or EPL for car parking, Council may allow the use of mechanical barriers such as flood gates. Where a mechanical barrier is permitted:

- a) a 0.5m freeboard is provided
- b) the mechanical barrier is located wholly on private property
- c) the mechanical barrier may require the provision of an on-site queuing area (see Chapter E1 Parking and Access for further details)
- d) the mechanical barrier is designed such that, by default, it is in the “closed” position. That is, it opens only to allow vehicles to enter and exit the site.

Note: The mechanical barrier must be designed and installed by a suitably qualified practitioner. A positive covenant will be required for maintenance of the mechanical barrier.

- C4 Filling of the site, where acceptable to Council, may change the flood and/or coastal inundation risk for the subject land. The FPL and/or EPL controls is based on the new flood and/or coastal inundation risk as determined by the new site levels.

**Special consideration**

- C5 All FPLs and EPLs represent the minimum standard required for the development type. An applicant may seek to lower the minimum FPL and/or EPL. Such requests will be assessed on their merits. A Flood Risk Management Report and/or a Coastal Inundation Assessment, prepared by a suitably qualified practitioner, will be required.

**Note:**

A Flood Risk Management Report and/or Coastal Inundation Assessment must be prepared by a suitably qualified practitioner and at a minimum it should include the following:

- ▶ acknowledgement that the proposed development seeks to lower the minimum standard FPL and/or EPL required by Council’s Stormwater Drainage and Flood Risk Management Development Control Plan;
- ▶ proposed risk management measures to minimise the impact of flooding and/or coastal inundation;
- ▶ demonstration that the risk management measures will not adversely affect other properties;
- ▶ an Emergency Management Plan that includes an evacuation strategy.

- C6 For ground level shop fronts in commercial and mixed-use developments, a lower the FPL and/or EPL may be considered to allow the development to match into existing longitudinal street levels, to optimise retail potential and/or to provide acceptable access for persons with disabilities. Such requests will be assessed on their merits. Driveway and footpath gradients must comply with Council’s specifications.
- C7 For heritage conservation properties, a lower FPL and/or EPL may be considered, for the heritage component of the building only, to remain sympathetic with the heritage values of the property. In general, any alterations and additions will be required to meet the FPL and/or EPL as outlined in conditions C1, C2, C3 and C4. Such requests will be assessed on their merits.

---

### E2.3.4 Flood controls

---

#### Objectives

- O1 To minimise risk to people and property.
- O2 To ensure that development does not cause flood levels to rise or exacerbate flooding on the surrounding floodplain.
- O3 To ensure existing overland flow paths are maintained and to ensure new structures do not obstruct the free flow of floodwaters.
- O4 To increase flood hazard awareness.
- O5 To reduce the long term risks associated with tidal inundation, elevated sea levels and/or waves overtopping foreshore defences.
- O6 To maintain Council's streetscape objectives in existing commercial and heritage areas.

#### Controls

##### *General controls which apply to all developments*

Note: A plan must accompany the application and provide information on any earthworks or filling of land (with suitable contour intervals) and the location of existing and proposed fences, retaining walls and/or any other barriers.

##### *General*

- C1 All structures have flood compatible building components below the 100 Year ARI level plus 0.5m freeboard.
- C2 All electrical equipment (e.g. air conditioners and pool pumps) is located or protected to above the 100 Year ARI level plus 0.5m freeboard.
- C3 All storage areas such as shelving are above the 100 Year ARI level plus 0.5m freeboard.
- C4 The structure is built to withstand the forces of floodwater, debris and buoyancy up to and including the 100 Year ARI level plus 0.5m freeboard.
- C5 Reliable evacuation access for pedestrians is provided from the lowest habitable floor area to a refuge area above the PMF level and designed to withstand PMF water forces.
- C6 Suitable flood protection (e.g. a crest up before descent on an access driveway) is provided within the subject site. Council will not generally allow alteration to existing levels on the public road or its property to achieve flood protection.

Note: The Building Code of Australia 2013 has requirements relating to minimum construction standards for specified building classifications in flood hazard areas. Reference should be made to the Code for further information.

*Fencing*

- C7 Fencing is constructed in a manner which does not change the nature or level of flood waters in the area. Fencing is of a permeable/open type design, however, existing solid fences may be replaced by new solid fences.
- C8 Fencing is adequately constructed so as to withstand the forces of floodwaters.
- C9 The flood impact of the development is considered to ensure that the development will not increase flood effects elsewhere. Where a significant change in use of the site is proposed, a flood impact assessment is required.

*Overland flow paths*

- C10 All overland flow paths are free of structures which prevent the free passage of overland flow.
- C11 All overland flow paths are designed to convey the 1 in 100 ARI event.
- C12 All existing overland flow paths are maintained and the hydraulic capacity of the openings between buildings is maintained.
- C13 Overland flow paths are provided on all properties that have upstream contributing catchments of 1,000m<sup>2</sup> or greater.
- C14 All overland flow paths are designed to a low hazard classification if possible.
- C15 Overland flow paths are designed such that they do not increase velocity or concentrate water on any adjacent property.
- C16 In overland flow paths, fencing is generally not be permissible. However, in low and medium flood risk precincts permeable/open type fences may be approved where it can be demonstrated that there will be no adverse impact on flooding to the subject land or surrounding properties.
- C17 Any structure located in an overland flow path is designed to be structurally sound in all flood events. A flood study may be required. Structures are designed by a suitably qualified practitioner.
- C18 If an overland flow path is not achievable, a 1 in100 ARI drainage system may be accepted as an alternative.
- C19 Overland flow paths are grass turfed.
- C20 In (sandy) areas with high risk erosion potential, overland flow paths are designed to limit velocity and/or protect against scour.

Note: Provisional hazard classifications are defined in Appendix L of the Floodplain Development Manual.

*Time limit consents*

C21 Where an applicant cannot increase EPLs to take into account the sea level rise planning benchmarks, Council may consider imposing time-limited consent to provide the potential to remove, replace or adapt development in the future. The consent will require the development to cease and all structures to be demolished and removed and the site to be reinstated to a sustainable landscaped form unless a further consent is obtained allowing for the continuation of the development in its originally approved or modified form. Council will consider the appropriateness of such developments on the merits of individual applications.

Note: It is likely that Council would impose a condition which identifies an appropriate and specific trigger which would require the removal of the development. For example, if the sea level were to reach a specified height or the erosion of an escarpment receding to a specified distance from the property boundary.

Repealed by WDCP Amendment No. 30 on 2 December 2024

**High flood risk precincts**

Note: The high flood risk precinct is where high flood damages, potential risk to life and/or evacuation problems would be anticipated or where development would significantly or adversely alter flood behaviour. Development in this precinct requires detailed risk management strategies and careful design to reduce the risk to life and property to an acceptable level.

The High FRP would generally be reflected by the following criteria:

- ▶ all areas where high hazard conditions occur during a 100 year ARI flood (using the provisional hazard categories published in Appendix L of the Floodplain Development Manual);
- ▶ all locations where safe evacuation routes cannot be provided by the natural topography, necessitating the need for refuge areas to be provided; and
- ▶ all floodways.

**FIGURE 2** Provisional hydraulic hazard categories  
Source: Floodplain Development Manual

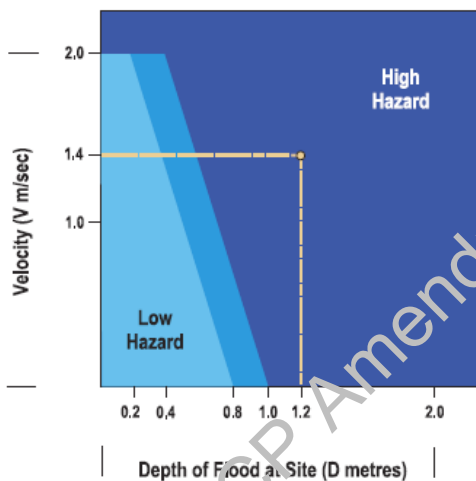

**Notes:**

The degree of hazard may be either:

- ▶ Reduced by establishment of an effective flood evacuation procedure;
- ▶ Increased if evacuation difficulties exist.

In the transition zone highlight by the median colour, the degree of hazard is dependant on site conditions and the nature of the proposed development.

**Example:**

If the depth of flood water is **1.2m** and the velocity of floodwater is **1.4m/sec** then the provisional hazard is **high**.

C22 Properties within a high flood risk precinct are unsuitable for all development (except alterations and additions (only) developments) unless a Flood Risk Management Report has been prepared, by a suitably qualified practitioner, outlining appropriate risk management measures.

C23 Buildings or structures constructed in high flood risk precincts are designed to withstand the PMF event.

C24 No new fencing of any type is permitted in high flood risk precincts unless it can be demonstrated, by a suitably qualified practitioner, that there will be no adverse impact on flooding to the subject land or surrounding properties.

---

**Medium flood risk precincts**

Note: The medium risk precinct includes all land that is inundated by the 100 year ARI flood that is not classified as high risk. Areas on the edge of the identified 100 year ARI floodplain where the topography provides low hazard rated excavation routes (using the provisional hazard criteria published in Appendix L of the Floodplain Development Manual) would generally be classified as medium risk.

- C25 Properties within a medium flood risk precinct are generally unsuitable for critical and sensitive use development. Such developments will be considered on their merits, taking into account any proposed risk management measures.
- C26 In medium flood risk precincts, impervious and continuous fencing is not permissible unless it can be demonstrated that there will be no adverse impact on flooding to the subject land or surrounding land.

**Low flood risk precincts**

Note: In the low flood risk precinct the likelihood of damages, occurring from flooding, is low. This area can be identified as land within the floodplain that is above the 100 year ARI flood but below the extent of the PMF.

- C27 For critical and sensitive developments in low flood risk precincts, all habitable and non-habitable floor levels are no lower than the PMF flood level.
- C28 For critical and sensitive developments in low flood risk precincts, all structures have flood compatible building components below the PMF flood level.
- C29 For critical and sensitive developments in low flood risk precincts, the applicant is to demonstrate that any structure can withstand the forces of floodwater, debris and buoyancy up to and including the PMF flood level.



**Other flood prone properties**

Note: There are four main floodplains within the Woollahra Municipality: Rushcutters Bay, Double Bay, Rose Bay and Watsons Bay. A property may be flood prone if it is outside of the identified four floodplains, but subject to overland flows due to one of the following characteristics:

- ▶ the property is on the low side of the road and/ or the boundary levels are below the level of Council’s kerb;
- ▶ the property is lower than surrounding properties;
- ▶ the property is in a natural low point, gully or depression; or
- ▶ the property is adjacent to or contains a flow path, open channel, watercourse or drainage line.

A property may also be flood prone if it is outside of the identified four floodplains, but subject to one of the following characteristics:

- ▶ the property fronts Sydney Harbour with any part of the land below RL 3.35m AHD;
- ▶ the development includes underground habitable areas; or
- ▶ the development includes a low level driveway or an underground car park.

C30 Where a property is outside of the four flood plains, but identified as flood prone, a site specific assessment is required. A flood analysis may be requested to determine the level of flood risk and to allow the setting of FPLs.

Note: A Flood Risk Management Report prepared, by a suitably qualified practitioner, outlining appropriate risk management measures may be required.

Repealed by WDCP Amendment No. 30 on 2 December 2024

## Appendix 1 – Definitions

The definitions in this appendix define words and expressions for the purpose of this chapter.

Other terms may be defined in other parts of the DCP, the Woollahra LEP 2014, and other publications including the NSW Government's Floodplain Management Manual: The Management of Flood Liable Land.

|  |   |
|--|---|
| <b>absorption system</b>                             | an excavation that has been filled with material or prefabricated void units that are conducive to the drainage of stormwater and which are designed to drain vertically or side-ways, into adjacent sub-surface in-situ void or fill material.   |
| <b>alterations and additions (only) developments</b> | <p>applies to the following developments:</p> <ul style="list-style-type: none"> <li>▶ residential development where the proposed development is an addition and/or alteration to an existing dwelling of not more than 40m<sup>2</sup> or 10% (whichever is the lesser) of the habitable floor area which existed at the date of commencement of this DCP;</li> <li>▶ development other than residential where the proposed development is an addition to existing buildings of not more than additional 100m<sup>2</sup> or 10% (whichever is the lesser) of the floor area which existed at the date of commencement of this DCP (whichever is the lesser).</li> </ul> |
| <b>charged or siphonic systems</b>                   | use the height of the building to create a pressurised stormwater system. This allows the system to draw water out of the gutters at higher velocities and flow rates. The drainage line permanently holds water.   |
| <b>coastal inundation</b>                            | is the storm-related flooding of coastal lands by ocean waters due to elevated still water levels (storm surge) and wave run-up.  |
| <b>commercial and mixed-use development</b>          | applies to all properties zoned Neighbourhood Centre, Local Centre, Mixed Use in Woollahra LEP 2014.  |

**critical and sensitive developments**

applies to the following types of developments: Emergency services facilities; public administration building that may provide an important contribution to the notification or evacuation of the community during flood events (e.g. SES Headquarters and Police Stations); hospitals; community facility; telecommunications facility; institutions; educational establishments; child care facilities; liquid fuel depot; public utility undertaking (including electricity generating works; sewerage treatment plant; sewerage system; telecommunications facility; utility installations and water treatment facility) which are essential to evacuation during periods of flood or if affected would unreasonably affect the ability of the community to return to normal activities after flood events; residential care facility; school and seniors housing.

**developments creating high levels of pollutants**

may include, but is not limited to the following: service stations; motor repair shops; panel beaters; miscellaneous automotive; marinas; boatsheds; marine repairs; shipbuilders; commercial slipways; miscellaneous retailers and manufacturers involving chemicals, solvents, hazardous waste and containers, miscellaneous retailers and manufacturers involving garden and building materials; vehicle depots; and car parks.

**enclosed car parking**

car parking which is potentially subject to rapid inundation, which consequently increases danger to human life and property damage (such as basement of bonded car parking areas). The following criteria apply for the purposes of determining what is enclosed car parking:

- flooding of surrounding areas may raise water levels above the perimeter which encloses the car park (normally the entrance), resulting in rapid inundation of the car park to depths greater than 0.8m, and
- drainage of accumulated water in the car park has an outflow discharge capacity significantly less than the potential inflow capacity.

**Epoch**

for determining design flood levels refers to a year in the future for which flood level probabilities are calculated. For example, the notation 100 Year ARI 2050 refers to the 100 year ARI flood level (or 1% AEP flood level) at the Year 2050 Epoch. This is a prediction made now (based on the best available information) of the flood level which has a 1% probability of occurring or being exceeded in 2050. Similarly, the Year 2100 Epoch refers to the flood level which has a 1% probability of occurring or being exceeded in 2100.

**flood evacuation strategy**

the proposed strategy for the evacuation of flood prone areas.

---

|                                    |   |
|------------------------------------|---|
| <b>flood risk precincts (FRPs)</b> | are a categorisation of a site's flood risk for land-use planning purposes. All property within a floodplain falls into one of three classifications: low, medium or high.  |
| <b>foreshore developments</b>      | includes all properties with any part of their land below RL 3.35m AHD.   |
| <b>foreshore inundation</b>        | the inundation of land occurring when water from Sydney Harbour overflows the natural or human-made foreshore boundary. All properties with any part of their land below RL 3.35m AHD may be impacted by foreshore inundation.  |
| <b>freeboard</b>                   | a factor of safety typically used in relation to the setting of flood planning levels. It compensates for uncertainties in the estimation of flood levels across the floodplain, such as wave action, localised hydraulic behaviour and impacts that are specific event related, such as levee and embankment settlement, and other effects such as sea level rise.                   |
| <b>green roofs</b>                 | a roof system, with a dual function. It designed to promote the growth of various forms of vegetation on the top of buildings. It is also designed to support various forms of renewable energy and water collection technology to assist in supplying power and water to the occupants of the building.  |
| <b>habitable floor area</b>        | as defined in the Floodplain Development Manual: The Management of Flood Liable Land.   |
| <b>local overland flooding</b>     | as defined in the Floodplain Development Manual: The Management of Flood Liable Land.<br><br>Note: All properties containing a Council owned pipe and/ or a drainage easement are subject to local overland flooding. All properties with low level driveways, footpaths or where their boundary levels are below the level of Council's kerb are subject to local overland flooding. |
| <b>low level property</b>          | any property where the property falls away from the road reserve. That is, the grade or level of the land generally falls from the front to rear boundary. Stormwater from the property generally falls towards a neighbour's property at the side or rear (rather than to Council's road).   |

---

---

|  |  |
|--|--|
| <b>mainstream flooding</b>             | <p>as defined in the Floodplain Development Manual: The Management of Flood Liable Land.</p> <p>Note: Properties that are situated adjacent to an open or covered channel or watercourse may be impacted by mainstream flooding.</p>   |
| <b>major alterations and additions</b> | <p>applies to the following developments:</p> <ul style="list-style-type: none"> <li>► residential development where the proposed development is an addition and/or alteration to an existing dwelling of more than an additional 40m<sup>2</sup> or 10% (whichever is the lesser) of the habitable floor area which existed at the date of commencement of this DCP;</li> <li>► development other than residential where the proposed development is an addition to existing buildings of more than an additional 100m<sup>2</sup> or 10% (whichever is the lesser) of the floor area which existed at the date of commencement of this DCP (whichever is the lesser).</li> </ul> |
| <b>on-site detention systems</b>       | <p>holding ponds that temporarily store stormwater to control and reduce downstream flow rates. They are designed to retard stormwater during intense rainfall and to empty once the peak of the storm has passed.</p>   |
| <b>overland flow paths</b>             | <p>above ground drainage paths that form a critical part of the drainage system. They convey stormwater when the stormwater volume is greater than the designed pipe systems capacity.</p>   |
| <b>pervious surface</b>                | <p>a paving system that allows water to infiltrate through pores in the pavement and is stored in voids until it can percolate through the natural ground. Pervious surfaces include, but are not limited to, porous asphalt, porous concrete and modular pavers.</p>  |
| <b>pump and sump systems</b>           | <p>a pump that is used to remove water that has accumulated in a sump basin, often in underground areas such as car parks. The sump pump is used to send water away from the house.</p>  |
| <b>rain garden</b>                     | <p>a planted depression that captures rainwater runoff from impervious urban areas such as car parks. The rain garden serves two main purposes. It reduces stormwater runoff through absorption into the ground and transpiration. Secondly, the plants grown within the rain gardens capture pollutants and reduce the amount of pollution which is then released to Council's stormwater system.</p>   |
| <b>refuge area</b>                     | <p>an area of land located above the PMF that provides reasonable shelter for the likely occupants of the development commensurate with the period of time that refuge is likely to be required in floods up to the PMF.</p>   |

---

---

|   |   |
|---|---|
| <b>residential development</b>            | applies to all properties zoned Low Density Residential and Medium Density Residential in Woollahra LEP 2014.   |
| <b>site emergency response flood plan</b> | a management plan that demonstrates the ability to safely evacuate persons and includes a strategy to move goods above the flood level within the available warning time. This Plan must be consistent with any relevant flood evacuation strategy, flood plan or similar plan.   |
| <b>stormwater</b>                         | untreated rain water that runs off the land onto which it falls.  |
| <b>suitably qualified practitioner</b>    | a professional with the appropriate qualifications, experience and skills to undertake the task. All suitably qualified practitioners should have appropriate professional indemnity insurance.   |
| <b>wave run-up and overtopping</b>        | the process where a wave reaches the foreshore, and an “uprush” of water onto the foreshore will occur. The height of wave run-up is affected by the nature of the foreshore. In some instances a wave may propagate over the foreshore edge and further landward, which is called wave overtopping. Wave run-up cannot occur up a vertical seawall and in these cases the hazard is related exclusively to wave overtopping. |

## Appendix 2 – Design rainfall intensities

The following design rainfall intensities are to be used throughout the municipality.

### Woollahra Council design rainfall intensities

| Duration |       | Average recurrence interval     |        |        |         |         |         |          |
|----------|-------|---------------------------------|--------|--------|---------|---------|---------|----------|
|          |       | 1 in 1                          | 1 in 2 | 1 in 5 | 1 in 10 | 1 in 20 | 1 in 50 | 1 in 100 |
| Minutes  | Hours | Rainfall intensities in mm/hour |        |        |         |         |         |          |
| 5        | 0.083 | 104                             | 133    | 167    | 187     | 213     | 246     | 271      |
| 6        | 0.100 | 98                              | 125    | 157    | 175     | 199     | 231     | 254      |
| 7        | 0.117 | 92                              | 118    | 148    | 166     | 189     | 219     | 241      |
| 8        | 0.133 | 88                              | 112    | 141    | 158     | 180     | 209     | 231      |
| 9        | 0.150 | 84                              | 107    | 135    | 151     | 173     | 201     | 222      |
| 10       | 0.167 | 80                              | 102    | 130    | 146     | 166     | 193     | 214      |
| 11       | 0.183 | 77                              | 99     | 125    | 140     | 161     | 187     | 207      |
| 12       | 0.200 | 74                              | 95     | 121    | 136     | 156     | 181     | 201      |
| 13       | 0.217 | 72                              | 92     | 117    | 132     | 151     | 176     | 195      |
| 14       | 0.233 | 69                              | 89     | 114    | 128     | 147     | 171     | 190      |
| 15       | 0.250 | 67                              | 86     | 111    | 124     | 143     | 167     | 185      |
| 16       | 0.267 | 65                              | 84     | 108    | 121     | 139     | 162     | 180      |
| 17       | 0.283 | 64                              | 82     | 105    | 118     | 136     | 159     | 176      |
| 18       | 0.300 | 62                              | 80     | 102    | 115     | 133     | 155     | 172      |
| 19       | 0.317 | 60                              | 78     | 100    | 113     | 130     | 152     | 168      |
| 20       | 0.333 | 59                              | 76     | 98     | 110     | 127     | 148     | 165      |
| 21       | 0.350 | 57                              | 74     | 95     | 108     | 124     | 145     | 162      |
| 22       | 0.367 | 56                              | 72     | 93     | 106     | 122     | 143     | 159      |
| 23       | 0.383 | 55                              | 71     | 91     | 104     | 119     | 140     | 156      |
| 24       | 0.400 | 54                              | 69     | 90     | 101     | 117     | 137     | 153      |
| 25       | 0.417 | 53                              | 68     | 88     | 100     | 115     | 135     | 150      |
| 26       | 0.433 | 52                              | 67     | 86     | 98      | 113     | 132     | 147      |
| 27       | 0.450 | 51                              | 65     | 85     | 96      | 111     | 130     | 145      |
| 28       | 0.467 | 50                              | 64     | 83     | 94      | 109     | 128     | 143      |
| 29       | 0.483 | 49                              | 63     | 82     | 93      | 107     | 126     | 140      |
| 30       | 0.500 | 48                              | 62     | 80     | 91      | 105     | 124     | 138      |
| 31       | 0.517 | 47                              | 61     | 79     | 90      | 104     | 122     | 136      |
| 32       | 0.533 | 46                              | 60     | 78     | 88      | 102     | 120     | 134      |

| Duration |       | Average recurrence interval     |        |        |         |         |         |          |
|----------|-------|---------------------------------|--------|--------|---------|---------|---------|----------|
|          |       | 1 in 1                          | 1 in 2 | 1 in 5 | 1 in 10 | 1 in 20 | 1 in 50 | 1 in 100 |
| Minutes  | Hours | Rainfall intensities in mm/hour |        |        |         |         |         |          |
| 33       | 0.550 | 46                              | 59     | 77     | 87      | 101     | 118     | 132      |
| 34       | 0.567 | 45                              | 58     | 75     | 86      | 99      | 117     | 130      |
| 35       | 0.583 | 44                              | 57     | 74     | 84      | 98      | 115     | 128      |
| 36       | 0.600 | 43                              | 56     | 73     | 83      | 96      | 113     | 126      |
| 37       | 0.617 | 43                              | 55     | 72     | 82      | 95      | 112     | 125      |
| 38       | 0.633 | 42                              | 55     | 71     | 81      | 94      | 110     | 123      |
| 39       | 0.650 | 42                              | 54     | 70     | 80      | 92      | 109     | 121      |
| 40       | 0.667 | 41                              | 53     | 69     | 79      | 91      | 107     | 120      |
| 41       | 0.683 | 40                              | 52     | 68     | 78      | 90      | 106     | 118      |
| 42       | 0.700 | 40                              | 52     | 67     | 77      | 89      | 105     | 117      |
| 43       | 0.717 | 39                              | 51     | 67     | 76      | 83      | 103     | 115      |
| 44       | 0.733 | 39                              | 50     | 66     | 75      | 87      | 102     | 114      |
| 45       | 0.750 | 38                              | 50     | 65     | 74      | 86      | 101     | 113      |
| 46       | 0.767 | 38                              | 49     | 64     | 73      | 85      | 100     | 111      |
| 47       | 0.783 | 37                              | 48     | 63     | 72      | 84      | 99      | 110      |
| 48       | 0.800 | 37                              | 48     | 63     | 71      | 83      | 97      | 109      |
| 49       | 0.817 | 37                              | 47     | 62     | 70      | 82      | 96      | 108      |
| 50       | 0.833 | 36                              | 47     | 61     | 70      | 81      | 95      | 106      |
| 51       | 0.850 | 36                              | 46     | 60     | 69      | 80      | 94      | 105      |
| 52       | 0.867 | 35                              | 46     | 60     | 68      | 79      | 93      | 104      |
| 53       | 0.883 | 35                              | 45     | 59     | 67      | 78      | 92      | 103      |
| 54       | 0.900 | 35                              | 45     | 59     | 67      | 77      | 91      | 102      |
| 55       | 0.917 | 34                              | 44     | 58     | 66      | 77      | 90      | 101      |
| 56       | 0.933 | 34                              | 44     | 57     | 65      | 76      | 89      | 100      |
| 57       | 0.950 | 33                              | 43     | 57     | 65      | 75      | 89      | 99       |
| 58       | 0.967 | 33                              | 43     | 56     | 64      | 74      | 88      | 98       |
| 59       | 0.983 | 33                              | 42     | 56     | 63      | 74      | 87      | 97       |
| 60       | 1     | 32                              | 42     | 55     | 63      | 73      | 86      | 96       |
| 90       | 1.5   | 25                              | 33     | 43     | 49      | 57      | 67      | 75       |
| 120      | 2     | 21                              | 27     | 36     | 41      | 47      | 56      | 63       |
| 180      | 3     | 16                              | 21     | 27     | 31      | 36      | 43      | 48       |
| 240      | 4     | 13                              | 17     | 22     | 26      | 30      | 35      | 39       |
| 300      | 5     | 11                              | 15     | 19     | 22      | 26      | 30      | 34       |



| Duration |       | Average recurrence interval     |        |        |         |         |         |          |
|----------|-------|---------------------------------|--------|--------|---------|---------|---------|----------|
|          |       | 1 in 1                          | 1 in 2 | 1 in 5 | 1 in 10 | 1 in 20 | 1 in 50 | 1 in 100 |
| Minutes  | Hours | Rainfall intensities in mm/hour |        |        |         |         |         |          |
| 360      | 6     | 10                              | 13     | 17     | 19      | 23      | 27      | 30       |
| 720      | 12    | 6                               | 8      | 11     | 12      | 14      | 17      | 19       |
| 1440     | 24    | 4                               | 5      | 7      | 8       | 9       | 11      | 12       |
| 2880     | 48    | 3                               | 3      | 4      | 5       | 6       | 7       | 8        |
| 4320     | 72    | 2                               | 3      | 3      | 4       | 4       | 5       | 5        |

Probable maximum precipitation depth in mm

| Duration |       | Catchment area   |                  |                  |
|----------|-------|------------------|------------------|------------------|
| Minutes  | Hours | 1km <sup>2</sup> | 2km <sup>2</sup> | 3km <sup>2</sup> |
| 15       | 0.25  | 170              | 160              | 160              |
| 30       | 0.5   | 250              | 240              | 230              |
| 60       | 1     | 360              | 350              | 340              |
| 90       | 1.5   | 460              | 450              | 440              |
| 120      | 2     | 540              | 530              | 520              |
| 180      | 3     | 660              | 640              | 630              |
| 360      | 6     | 870              | 850              | 830              |