

## Chapter E7 Signage

Part E ► General Controls for All Development

CHAPTER E7 APPROVED ON 27 APRIL 2015

AND COMMENCED ON 23 MAY 2015

Repealed by WDCP 2015 Amendment No.24 on 31 May 2024

## Chapter E7 ▶ Signage

### Contents

<b>E7.1</b>	<b>INTRODUCTION</b> .....	<b>1</b>
	E7.1.1 Land where this chapter applies .....	1
	E7.1.2 Development types that this chapter applies to.....	1
	E7.1.3 Objectives .....	2
	E7.1.4 Relationship to other parts of the DCP .....	2
	E7.1.5 Relationship to other documents.....	2
<b>E7.2</b>	<b>GENERAL SIGNAGE CONTROLS—ALL AREAS</b> .....	<b>3</b>
	E7.2.1 Building identification signs and business identification signs .....	4
	E7.2.2 When external painting of a building constitutes a wall sign .....	10
<b>E7.3</b>	<b>HERITAGE CONSERVATION AREAS AND ON HERITAGE ITEMS</b> .....	<b>11</b>
	E7.3.1 Signage in heritage conservation areas and on heritage items .....	12

Repealed by WDCP 2015 Amendment No.24 on 31 May 2024

Repealed by WDCP 2015 Amendment No.24 on 31 May 2024

## E7.1 Introduction

Signage includes an advertising structure, a building identification sign and a business identification sign. Under Woollahra Local Environmental Plan 2014 (Woollahra LEP), building identification signs and business identification signs are the only signs permitted in the Woollahra Municipality.

In Woollahra LEP these signs are defined as:

- ▶ “building identification sign” means a sign that identifies or names a building and that may include the name of a building, the street name and number of a building, and a logo or other symbol but does not include general advertising of products, goods or services.
- ▶ “business identification sign” means a sign:
  - a) that indicates:
    - (i) the name of the person or business, and
    - (ii) the nature of the business carried on by the person at the premises or place at which the sign is displayed; and
  - b) that may include the address of the premises or place and a logo or other symbol that identifies the business, but that does not contain any advertising relating to a person who does not carry on business at the premises or place.

This chapter identifies Council’s requirements for signage, addressing matters such as the type of sign, content, size, location and colour to ensure that signage communicates effectively and makes a positive contribution to the public domain.

### E7.1.1 Land where this chapter applies

This chapter applies to all land within the Woollahra Municipality.

### E7.1.2 Development types that this chapter applies to

Woollahra LEP 2014 only permits building identification signs and business identification signs; general advertising signs are prohibited.

This chapter applies to building identification signs and business identification signs that require consent, or that form part of other works that require consent.

This chapter does not apply to small scale and low impact signage identified as exempt development in Woollahra LEP 2014, Schedule 2 or *State Environmental Planning Policy (Exempt and Complying Development Codes) 2008*. However, if the requirements and development standards in the Codes SEPP or Woollahra LEP 2014 cannot be met, development consent is required and the provisions of this DCP chapter apply.

### E7.1.3 Objectives

---

The objectives of this chapter are:

- 01 To control the erection of building signs and business identification signs.
- 02 To ensure that signage conveys messages reasonable and relevant for the purpose of identifying buildings and individual businesses.
- 03 To ensure that signage in the centres is unobtrusive, informative and compatible with an attractive shopping environment.
- 04 To ensure that the location, size, colour and content of signs does not cause unreasonable visual clutter, or detract from the character of the building to which it is attached or the streetscape in which it is located.
- 05 To identify when external painting of a building constitutes a wall sign.

### E7.1.4 Relationship to other parts of the DCP

---

This chapter is to be read in conjunction with the other parts of the DCP that are relevant to the development proposal, including:

- ▶ If located in a residential area or heritage conservation area—the controls in Part B: General Residential, or Part C: Heritage Conservation Areas that apply to the land. Additional signage controls apply in some heritage conservation areas (HCA), such as William Street in Paddington. If there is an inconsistency between the controls in this chapter and the controls in Part C, the controls in Part C for the HCAs prevail.
- ▶ If located in a business centre—the controls in Part D: Business Centres that apply to the land.
- ▶ Part F: Land Use Specific Controls - this part contains chapters on Child Care Centres, Educational Establishments, Licensed Premises and Telecommunications.

### E7.1.5 Relationship to other documents

---

#### *State Environmental Planning Policy (Exempt and Complying Development Codes) 2008 (Codes SEPP)*

The Codes SEPP contains Division 2 Advertising and Signage Exempt Development Code. Under the code, common types of building and business identification signs and other signs, such as community notices and real estate signs, are exempt development if the standards are met.

#### **Woollahra LEP 2014**

Under Woollahra LEP 2014, Schedule 2, small scale and low impact building identification and wall signs may be undertaken as exempt development in heritage conservation areas or on heritage items if the criteria and standards are met.

## E7.2 General signage controls—all areas

Signage is essential to commercial premises, and suitable signage can add interest, character and vitality to the built environment. However poorly designed or placed signs, or too many signs in one location, can affect streetscape amenity.

It is important that commercial operators thinking about signage for their premises remember that acceptability of an impact depends not only on the extent of the impact but also on reasonableness of, and necessity for, the development that causes it. In other words, how many signs are reasonably required to convey the message that the premises is operating from the site?

Signage should never dominate and overwhelm the character of the street. It is important for signage to be well designed, appropriate in scale, and of a quality that enhances the character of the area and helps define a local identity.

The signage should be integrated with the building design. The design, size and colour of signs must not dominate or obscure the architectural character and detail of the building or adjoining buildings. Generally signage should occur below the awning level as signage above the awning level impacts on the visual cohesion of the streetscape.

The objectives and controls in this section apply to signs in the centres and residential areas; additional controls for signage in heritage conservation areas (HCA) also apply, and are set out in Section 7.3 of this chapter. If there is an inconsistency between these general controls and the controls for the HCAs, the controls for the HCAs prevail.



**FIGURE 1** Types of signs

- 1 Building identification sign – located on the parapet
- 2 Building identification sign – located on the façade bay
- 3 Fascia sign
- 4 Under awning sign
- 5 Top hamper sign
- 6 Window sign

Buildings in Woollahra’s business zones are predominantly mixed use, with active retail uses at street level and residential or office uses above. Typically an awning separates the retail frontage from the upper levels. The façade of the upper levels should not be used to advertise the business at street level.



**FIGURE 2**  
Example of signage on awning, top hamper and windows

**E7.2.1 Building identification signs and business identification signs**

Objectives	Controls
<p>O1 To limit the types of signs on buildings to those signs that are less likely to contribute to visual clutter or be otherwise visually intrusive.</p>	<p>C1 The signage is:</p> <ul style="list-style-type: none"> <li>a) a building identification sign;</li> <li>b) a business identification sign that is:                             <ul style="list-style-type: none"> <li>i) wall sign (may be a flush wall or painted wall sign);</li> <li>ii) fascia sign, including a sun-blind attached to the outer edge of the fascia;</li> <li>iii) under awning sign;</li> <li>iv) top hamper sign;</li> <li>v) window sign.</li> </ul> </li> </ul> <p>Refer to Figure 1 above.</p>
<p>O2 To preserve the existing and future roofscapes and protect views.</p>	<p>C2 The signage is not one of the following types:</p> <ul style="list-style-type: none"> <li>a) roof or sky sign;</li> <li>b) vertical or horizontal projecting wall sign, other than a projecting wall sign in William Street as permitted in Part C of the DCP, Chapter C1 Paddington HCA;</li> </ul>



Objectives	Controls
	<ul style="list-style-type: none"> <li>c) pylon or pole sign;</li> <li>d) sky sign; or</li> <li>e) fin sign.</li> </ul>
<p>03 To ensure that signage conveys relevant messages and images and provides effective communication in suitable locations.</p>	<p>C3 The signage is fixed to a building that has been lawfully constructed.</p> <p>C4 The signage relates to uses that have been lawfully established.</p>
<p>04 To ensure that signage does not contribute to visual clutter or environmental degradation because of its content.</p>	<p>C5 The signage assists in way finding and pedestrian useability.</p> <p>C6 Signage relating to a particular business is attached to that section of the building occupied by that business.</p> <p>C7 The signage does not contain advertising that:                 <ul style="list-style-type: none"> <li>a) promotes products or services not related to the business being conducted on the site; or</li> <li>b) is for a single product, unless that product is the only merchandise being sold by the business.</li> </ul> </p> <p>C8 For a building identification sign, the content is limited to:                 <ul style="list-style-type: none"> <li>a) street number;</li> <li>b) name of the building; and</li> <li>c) one logo or graphic.</li> </ul> </p> <p>C9 For a business identification sign, the content is limited to:                 <ul style="list-style-type: none"> <li>a) street number;</li> <li>b) name and general nature of the business;</li> <li>c) name of the proprietor or business (or both); and</li> <li>d) one recognised logo or trade name (or both).</li> </ul> </p>

Objectives	Controls
	<p>C10 If a corporate logo or graphic appears as part of the signage, it is compatible with the architecture, materials, finishes and colours of the building, and does not have an adverse impact on the character of the building or streetscape.</p>
<p>O5 To ensure that signage is sympathetic to the design and architectural character of the building.</p>	<p>C11 The signage is integrated with the architectural design of the building, having regard to the building composition, fenestration, materials, finishes and colours.</p> <p>C12 The signage does not obscure or extend over any architectural, decorative or other distinguishing feature of the building.</p> <p>C13 The signage is of a high quality design and finish.</p>
<p>O6 To ensure that signs do not contribute to visual clutter or environmental degradation of the public domain because of the type, size or location.</p> <p>O7 To ensure that signage is limited to that reasonably required to convey the message that a particular business is operating from the premises.</p> <p>O8 To ensure that signs are an appropriate size and scale for the building on which they are erected.</p> <p>O9 To ensure that signage is compatible with its context.</p> <p>O10 To protect the amenity of residential development.</p> <p>O11 To ensure that window signs do not compromise active and desirable pedestrian environments.</p>	<p>C14 For signage on a building in a business zone, the total signage area does not exceed a factor of 0.5m<sup>2</sup> for each metre of the building width at its frontage to a public road.</p> <p>C15 For a building identification sign, the sign:</p> <ul style="list-style-type: none"> <li>a) is located on the main façade of the building;</li> <li>b) is designed as an integral part of the façade;</li> <li>c) may be located above awning height; and</li> <li>d) is generally composed of content that is affixed to the building.</li> </ul> <p>Note: Not all buildings will have a building identification sign.</p>

Objectives	Controls
<p>O12 To create an active interface between ground level retail or commercial properties and the street.</p>	<p>C16 For a business identification sign located in a business zone, the sign:</p> <ul style="list-style-type: none"> <li>a) is located in that part of the building occupied by the business;</li> <li>b) is primarily located on the awning fascia and under the awning height of the building. Signs, other than wall signs, above the awning height should be avoided;</li> <li>c) does not face a service lane; and</li> <li>d) is not located on a side wall abutting a residential property.</li> </ul> <p>C17 Where there are multiple occupancies or uses within a single building or site:</p> <ul style="list-style-type: none"> <li>a) a coordinated approach to the location and design of signs is taken; and</li> <li>b) a directory of tenants is provided at the ground floor level.</li> </ul> <p>C18 For an under awning sign located in a business zone, there is no more than one sign per premises and the sign:</p> <ul style="list-style-type: none"> <li>a) is a maximum height of 300mm;</li> <li>b) is a maximum length of 2.6m (or two thirds the width of the footpath, whichever is the lesser);</li> <li>c) is not lower than 2.6m from the footpath level as measured from the bottom of the sign; and</li> <li>d) is a minimum distance of 3m from adjoining under awning signs.</li> </ul> <p>C19 For a flush wall or painted wall sign located in a business zone, the sign:</p> <ul style="list-style-type: none"> <li>a) does not exceed 5m<sup>2</sup>;</li> <li>b) does not extend over or block windows or other openings in the building;</li> <li>c) does not project more than 150mm from the wall;</li> </ul>

Objectives	Controls
	<p>d) does not protrude above the parapet or eaves; and</p> <p>e) is not illuminated.</p> <p>C20 No more than one flush wall or painted wall sign on any elevation of the building.</p> <p>Note: The external painting of a building may constitute a painted wall sign where the painting uses corporate colours and can be reasonably considered as branding. Refer to Section 7.2.2 below for circumstances when painting of a building may be a painted wall sign.</p> <p>C21 For a servicing and delivery sign, the sign does not exceed an area of 0.35m<sup>2</sup>.</p> <p>C22 For a window sign, the sign:</p> <p>a) does not cover more than 40% of the surface of the window in which it is displayed; and</p> <p>b) if illuminated, is internally illuminated only.</p> <p>C23 Blanked out windows or location of shelving, fixtures, or the like, that do not provide for transparency into the premises and an attractive interface to the street are avoided.</p>
<p>O13 To ensure that signage in residential zones is discrete and does not impact on the residential character.</p> <p>O14 To ensure that the purpose of signage in residential areas is to identify the business, but does not seek to blatantly advertise the business.</p>	<p>C24 For a flush wall or painted wall sign in a residential zone that is for a business other than a home business, home industry or home occupation—the sign does not exceed an area of 2.5m<sup>2</sup>, and no more than one per building.</p> <p>C25 The signage is positioned parallel to the property boundary.</p>
<p>O15 To ensure that signage does not contribute to visual clutter or environmental degradation because of its colour.</p>	<p>C26 The colours in the signage are compatible with the architecture, materials, finishes and colours of the building.</p>

Objectives	Controls
<p>O16 To ensure that the colour of signage is compatible with the character of the streetscape and the desired future character of the area where the signage is located.</p>	<p>C27 The colours do not have an adverse impact on the character of the building or streetscape.</p> <p>C28 Corporate colours may appear as part of the sign, but are not used as the principal or dominant colour scheme.</p> <p>C29 Where there are multiple occupancies or uses within a single building, a coordinated colour scheme for signs is provided.</p>
<p>O17 To ensure that the location and size of signs do not affect public safety.</p> <p>O18 To ensure that the illumination of signage does not have an adverse impact on the amenity of the public domain or residential uses.</p> <p>O19 To ensure that signs do not cause unreasonable distraction.</p>	<p>C30 The signage does not obscure or interfere with safety, public directional or traffic signs.</p> <p>C31 Illuminated signage is avoided in the residential zones.</p> <p>C32 Illuminated signage or floodlighting of signs minimises lightspill and does not adversely affect amenity, particularly residential amenity.</p> <p>C33 If the sign is illuminated, the cabling is concealed or integrated with the sign.</p> <p>C34 In the B1 zone, illumination from a neighbourhood shop, such as a convenience store or the like does not exceed a maximum horizontal luminance of 200 lux.</p> <p>C35 Signage does not involve:                     <ul style="list-style-type: none"> <li>a) mechanical or animated flashing, pulsing or moving parts;</li> <li>b) neon tubes or fluorescent lighting (located either externally or in a shopfront window); or</li> <li>c) banners, flags or spotlights.</li> </ul> </p>

---

## E7.2.2 When external painting of a building constitutes a wall sign

---

Branding a building by painting the facade in the business corporate colours should be avoided.

Generally corporate colours involve bright or primary colours. Such colours, when painted over large areas on a building or above the awning level, can be loud and distracting and often do not provide a well-mannered and thoughtful contribution to the streetscape.

The corporate colours tend to be inconsistent with the character of the centre and the palette of colours predominantly used in the centre. Furthermore, bright and primary colours on buildings have the effect of adding to the perceived building bulk.

Individual business branding and identity in external painting and colour schemes is to be subordinate to the main colour scheme on the building.

Where it is established that a particular colour or combination of colours used to paint a building has the effect of a sign promoting a particular business, that work may be regulated through the development application process, and the provisions in this chapter of the DCP apply, specifically those controls for a painted wall sign.

### When the external painting of a building constitutes a wall sign

The external painting of a building is taken to constitute a wall sign if any of the following apply:

- a) The use of colours in patterns, symbols, messages or other devices promotes the business, a product, an event or an activity.
- b) The use of colours in patterns, symbols, messages or other devices conveys information, instructions or directions.
- c) When a business, activity or event is readily identifiable from a colour or a colour scheme and regularly uses that colour or colour scheme in its branding.

Painted and flat mounted wall signs tend to be visually prominent, particularly where the building is located on a corner site. It is therefore important that the size and location of these signs on the building are controlled to ensure that the sign is not intrusive or unreasonably dominant, having regard to the streetscape and desired future character of the centre.

### Controls for a painted wall sign

The controls for a flush wall sign are in Section 7.2 above. These controls, amongst other things, limit the size of the sign to 5m<sup>2</sup>.

### E7.3 Heritage conservation areas and on heritage items

Signage within heritage conservation areas and on heritage items is to be sympathetic with heritage significance of the place or item.

Traditionally, signage to retail and other commercial buildings was painted directly on building elements. Old photographs show that signs were painted on building wall parapet panels, verandah and awning fascias or directly onto glazing. Broadly there was an integration of signage with the building. The colour of the signs and signwriting typically included light brown, rich brown, Indian red, chrome green, and in rare instances Prussian blue, black and dark tints, and slate grey, as well as gold and silver leaf.

While replication of older signage is not the aim, reference to lettering styles, traditional locations and colours should be made.

Locating signs on buildings not originally intended for retail use is more difficult, and particular attention is needed as these signs have the potential for a greater impact on heritage significance.

The objectives and controls in this section apply in addition to the general controls in Section 7.2 above. If there is an inconsistency between these controls and the general controls, the controls in this section prevail. However, if there is an inconsistency between these controls and any control in Part C of the DCP on the heritage conservation areas, the controls in Part C prevail.

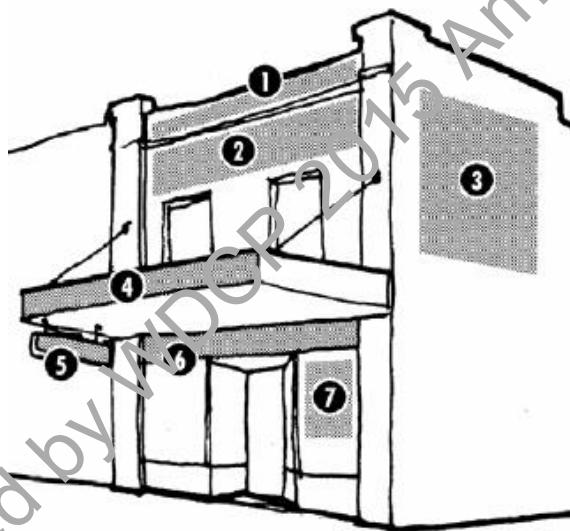

**FIGURE 3** Types of signs

- 1 Parapet sign
- 2 Upper level facade sign
- 3 Flush wall and painted wall sign
- 4 Fascia sign
- 5 Under awning sign
- 6 Top hamper sign
- 7 Window sign

### E7.3.1 Signage in heritage conservation areas and on heritage items

Objectives		Controls	
O1	To conserve existing signs which have heritage significance.	C1	Existing signs with heritage significance should be retained and conserved.
O2	To minimise the number of signs.	C2	Signs should be located on the traditional areas for signs in heritage conservation areas as shown in Figure 3 above.
O3	To provide for signs in appropriate locations on buildings.	C3	The number of signs is limited to those necessary to display the name of the business and/or proprietor and the name of the building (if applicable).
O4	To minimise the impact of signs on the heritage significance of individual buildings and the heritage conservation area generally.	C4	The content of the signage has minimum reference to the particular service provided or products retailed from the premises.
O5	To ensure that the size of signs do not dominate the architectural character of the building or adjoining buildings.	C5	Where the building contains more than two tenants, a directory of tenants is provided at ground floor level on a secondary external wall.
O6	To ensure that the size of signs respond appropriately to the physical context and historical background of the streetscape and HCA as a whole.	C6	For a painted window sign, the sign does not dominate or clutter the shop front window.
		C7	A painted window sign on an upper storey window may only be considered for the identification of tenants where appropriate wall surfaces or other areas for signage are not available.
		C8	For a top hamper sign, the sign: <ul style="list-style-type: none"> <li>a) may be painted;</li> <li>b) is flush to the external face of the shopfront where practicable, but in any case does not project more than 100mm;</li> <li>c) is a maximum 600mm wide;</li> <li>d) is a maximum 6000mm long; and</li> <li>e) terminates 600mm short of each side boundary.</li> </ul>



Objectives	Controls
	<p>C9 For a flush wall or painted wall sign, the sign:</p> <ul style="list-style-type: none"> <li>a) is not constructed or installed on a heritage item;</li> <li>b) does not exceed an area of 2.5m<sup>2</sup>; and</li> <li>c) is no more than one per building.</li> </ul> <p>C10 Notwithstanding C1-C9 above, for a sign in William Street, Paddington, on a residential building used for commercial purposes, the number and type of signs are set out in Refer to Part C of the DCP, Chapter C1 Paddington HCA.</p>
<p>O6 To ensure that signs do not dominate or obscure the architectural character and detail of a building or a group of buildings.</p> <p>O7 To ensure that design, style and colours of signs complement the historic character of the streetscape but not mimic historic signage.</p>	<p>C11 The signage is not directly fixed by any means to sandstone or face brickwork, but may be fixed into mortar joints.</p> <p>C12 The signage is not painted on original face brickwork, sandstone, terracotta and glazed or tessellated tiling, or any other surface that is traditionally unpainted or unfinished by other mediums.</p> <p>C13 No demolition of any part of the structure or building on the site may occur to accommodate the signage.</p> <p>C14 Materials are restricted to those which were traditionally used for signs, including painted timber or board, engraved metal plaque such as bronze or painted masonry. With the exception of metal plaque, these materials are characterised by their non-reflectively.</p> <p>C15 Colours used in the signage are suitable for the architectural style and period of the building. The use of fluorescent paints and iridescent colours are not appropriate.</p>

Objectives	Controls
	<p>C16 The design and style of lettering in the signage is suitable for the style of the building and the historic character of the area.</p> <p>C17 Where a number of tenancies occupy the same building or row of properties, the signage is consistent in regards to shape, background colour, size, fixing methods and lighting. Consistent fonts and graphics are encouraged.</p> <p>C18 Consistency in signs between neighbouring buildings which have a common architectural style, whether traditional or contemporary is encouraged.</p>
<p>O8 To ensure lighting or illumination of signs does not impact on the heritage fabric or presentation of the place.</p>	<p>C19 Where lighting is required, the sign is painted and externally spotlighted.</p> <p>C20 Internally lit signs, neon signs or signs with neon lettering are generally inappropriate and may only be considered if the sign is inside the shop window and is small and discrete.</p>

Repealed by WDCP 2015 Amendment No 24 on 31 May 2024